

AIR DIAPHRAGM PUMP

Equipment ID	ARP003
Equipment Description	2" Air Diaphragm Pump, c/w Skid
Model	M-Pump
Type	AIR DIAPHRAGM PUMP
Product Name	MB2AATTAB
Max Flow Rate	650 Liters/ Min
Air Inlet	(Female) 3/4" - 14 N.P.T.F. - 1
Fluid Inlet	2" A.N.S.I./DIN Flange
Fluid Outlet	2" A.N.S.I./DIN Flange
Max. operating pressure	125-psi (8.3-bar)
Weight	28.1 kg
Maximum dry suction lift	ft (m) 14 (4.27)
Material of Construction	Polypropylene
Center Body	SS 304
Diaphragm	PTFE
Frame	CS, Come with Drip Pan and 4 lifting Pad-Eye

PUMP CURVE

Jul. 24, 15

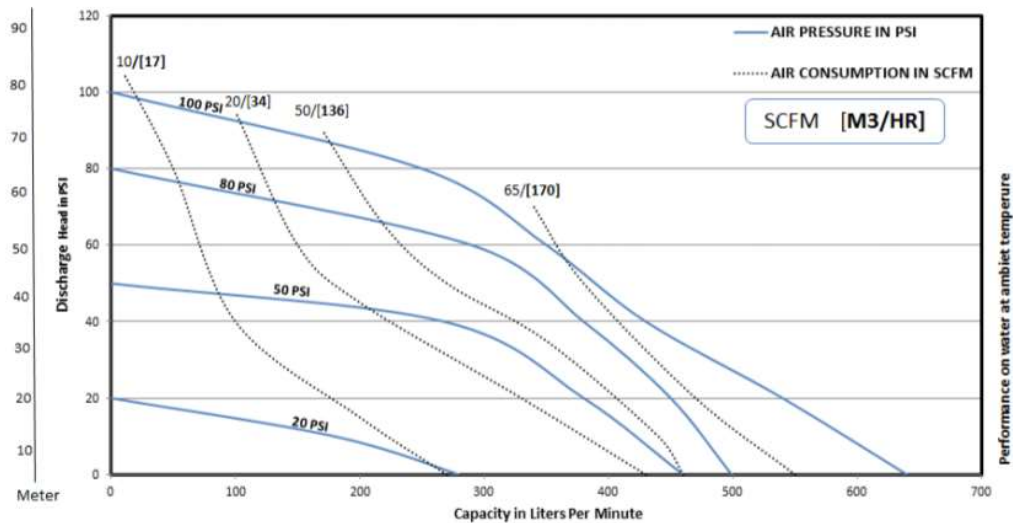

PUMP DIMENSION

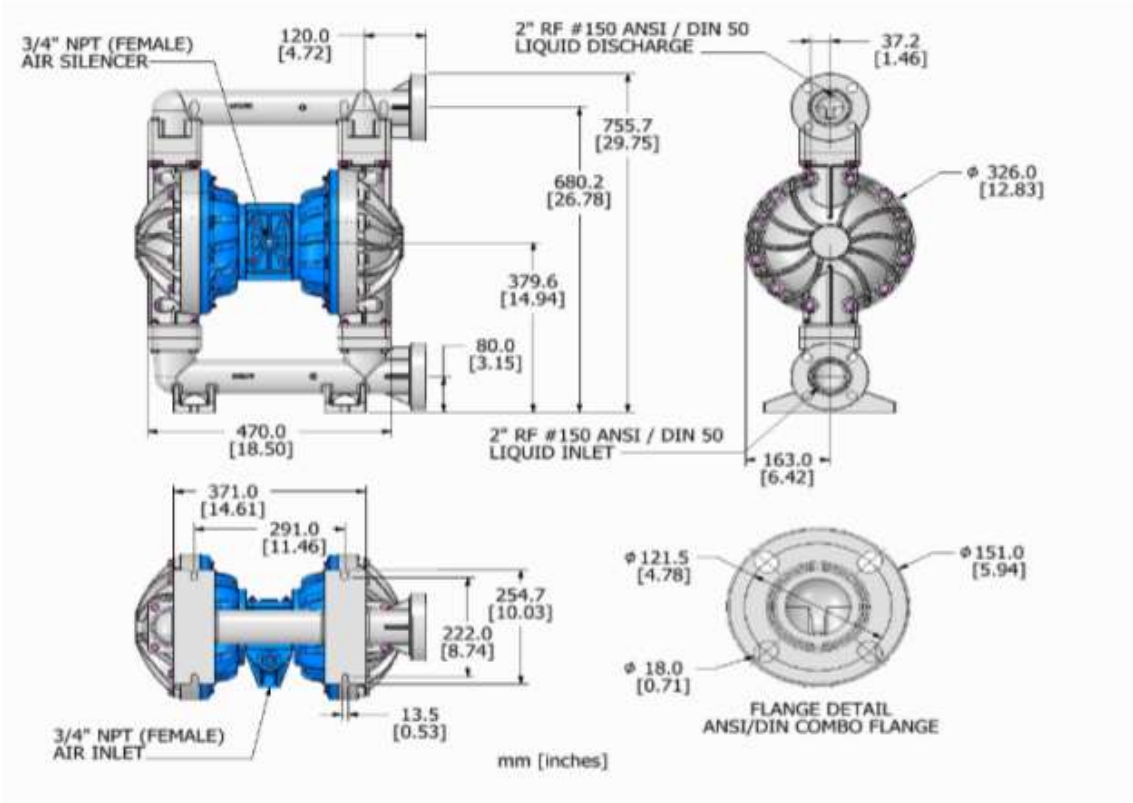

PICTURE

