

**EQUIPMENT DATA SHEET**

**120kV Heater**

**ELECTRIC HEATER**

Type	Hot Coil Heater
Brand	NTT
Model Number	MOS-50-100P-E4GV 480V 3P 2S
Flow Rate	32m3/h
Material	Stainless Steel 304L
Connection	8" Flange Mounted, SS 304, 150#
System Capacity	2000 L
Dry weight	700 kg
Size	1230mm (width) x 1526 mm (Length) x 1232 m (high)
Operating Temperature	60°C
Power Rating	120 kW x 415V / 3 Phase/ 2 Stage

**PICTURE**



## DETAIL DRAWING

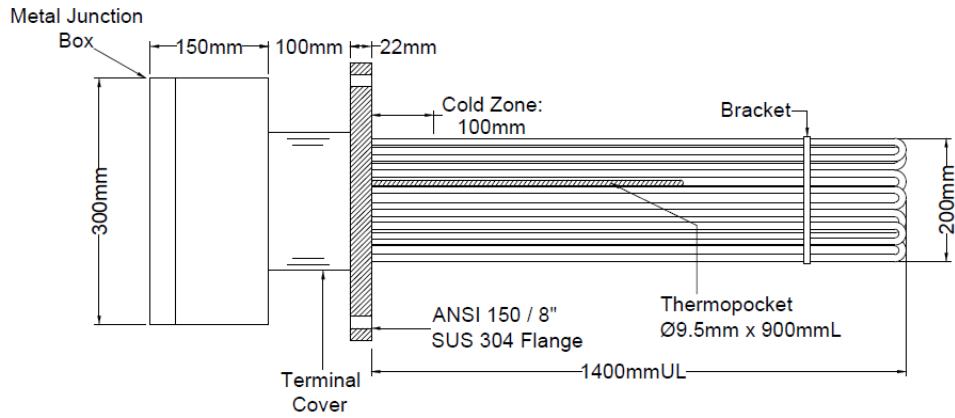

### FLANGED WATER HEATER

Power Rating: 120KW x 415V / 3 Phase / 2 Stages

Description

- 1) Dimension: Ø11.2mm x 1400mmUL x 18 Elements
- 2) Heater Material: SUS 316L
- 3) Connection: Delta Connection
- 4) Flange Size: ANSI 150 / 8" SUS 304
- 6) Quantity: 1 unit

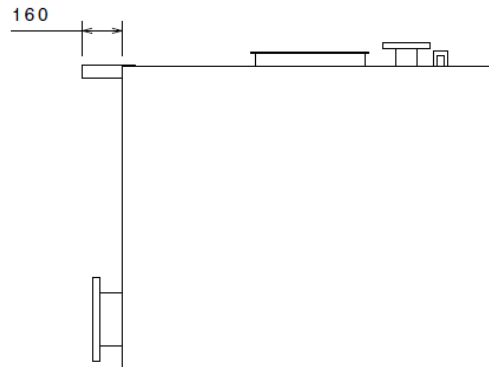
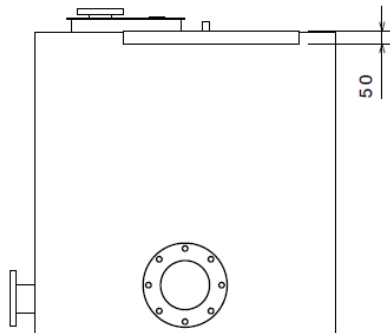
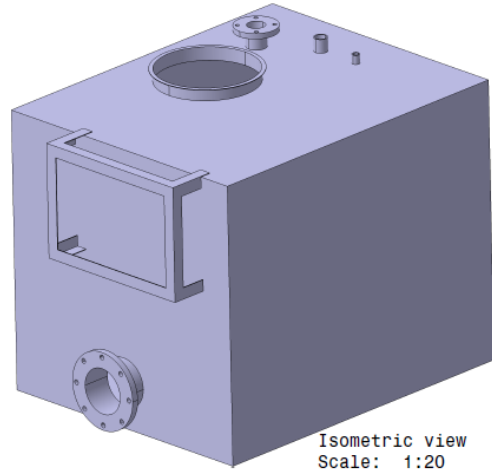
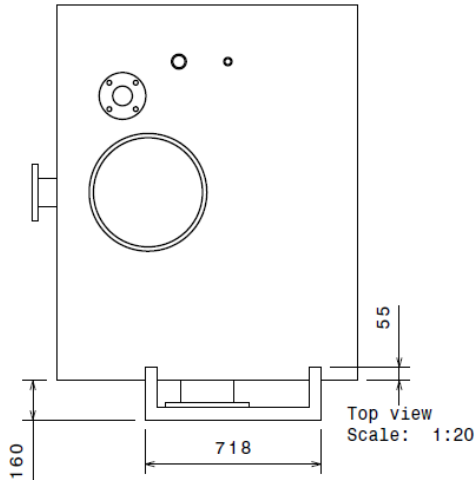

# CONTROL PANEL CIRCUIT DIAGRAM

## 120KW x 415V / 3 Phase / 2 Stages

